

Original Article

The mediating role of compassion for the others' lives in the relationship between the spouses' dark tetrad personality and verbal violence against women

Mozaffar Ghaffari^{1*} & Yousef Hazrati²

1. Department of Psychology, Faculty of Psychology & Educational Sciences, Payame Noor University (PNU), Iran.
2. Department of Linguistics, Faculty of human Sciences, Payame Noor University (PNU), Tehran, Iran.

Abstract

The present study was conducted with the aim of investigating the mediating role of compassion for the others' lives in the relationship between the spouses' dark tetrad personality and verbal violence against women. The research design of the study was correlational through structural equations. The population of the research constituted all the clients of the family court of Tabriz in 2022, two hundred persons from them were selected by using the availability sampling as the sample. In the data collection, the researcher-made questionnaire of verbal violence against women, the compassion for the others' lives questionnaire and Johnson and Webster's dark tetrad personality scale were used. The collected data was analyzed using Pearson correlation coefficient, Sobel and Bootstrap and through SPSS and AMOS software. The results showed that the dimensions of the spouses' dark tetrad personality in interaction with the mediating role of compassion for the others' lives play a role in explaining verbal violence against women which in total, 27% of the variance of verbal violence against women is explained through the variables of the model. The direct effect of compassion for the others' lives (0.19), Machiavellianism (0.10), psychopathy (0.24), narcissism (0.23), and spouses' sadism (0.23) are significant in estimating verbal violence against women. The indirect effect of Machiavellianism (t-value = 2.81), psychopathy (t-value = 2.99) and sadism (t-value = 2.98) of spouses with the mediation of compassion for the others' lives on the level of verbal violence against women is significant, but the indirect effect of narcissism is not significant. According to the result of the study, and in order to weaken the negative effects of dark personality in intensifying verbal violence against wives and wife abuse, it is necessary for husbands to be aware of the role of compassion for the others' lives and use it in solving marital, life and children issues.

Keywords

Compassion
Dark tetrad
personality
Verbal violence

Received: 2023/04/18

Accepted: 2023/11/30

Available Online: 2024/02/25

Introduction

In recent decades, violence which means the violence of a husband against a woman, has been raised as one of the important social, health and legal issues (Jafari & Parvin, 2022). Domestic violence is a serious issue throughout the world which affects many women regardless of their demographic characteristics (Ahmadi et al., 2023). The term violence against women has been used to describe a wide range of actions, including murder, sexual assault, emotional abuse, beating, trafficking, prostitution, profanity and humiliation (Hosseiniabadi et al., 2021). Verbal and psychological violence against women is considered an important sociological and legal problem and a serious threat within the context of basic human rights (Alkan et al., 2021). Verbal and lingual violence against women is one of the most widespread violations

of human rights. Violence against women has attracted the attention and sensitivity of governments and international organizations which has caused several documents to be approved in order to ban various types of violence against women (Güneş & Ezikoğlu, 2023).

A variable that may be effective on verbal and lingual violence against women is compassion for the others' lives. Compassion for the others' lives is awareness and feeling the pain and suffering of others (Weng et al, 2013). Compassion for the others' lives is a humanitarian orientation that aims to free fellow humans and the needy from pain, suffering, trouble and problems (Pommier, 2011). The four dimensions of compassion for the others' lives are: awareness and identification of the needs and plight of fellow human beings, sympathy with a needy and troubled person, wishing to solve all the needs and problems of the needy, and practical action to solve the

needs and problems of the needy (Chang et al., 2014). The direct and indirect effect of empathy and compassion with spouse has been significant on the amount of verbal and lingual violence against women and spousal abuse (Muralidharan & Kim, 2020). There is a statistically significant negative correlation between the total degrees of violence against the wife and the degrees of forgiveness with the husband and the total degrees of forgiveness of adult wives (El Sayed, 2023). Estimates of indirect effects indicated that affective empathy and cognitive empathy served as pathways through which IPV (Intimate partner violence) was linked to dimensions of traumatic bonding (Effiong et al., 2022).

Another variable that can be related to verbal and lingual violence against women and is not ineffective in this matter is the spouses' dark tetrad personality. Dark personality has four components. The first component is narcissism which refers to exaggerated feelings of arrogance, pride, self-indulgence, and self-righteousness. The second component is psychopathy, which is characterized by features such as impulsivity, sensationalism, callousness, arrogance, and interpersonal aggression. The third component is Machiavellianism, which reflects a highly selfish orientation in which a person tends to reach their goals by any means such as deception, fraud, and exploitation. sadism is the fourth component of dark personality traits that bullies look for opportunities to engage in cruel or harassing daily activities (Yousefi & Imanzad, 2018). Narcissism and psychopathy (dimensions of the four personality traits) are effective and related components of spousal abuse and marital disturbances (Khaksari, 2022). Dark personality directly and through the mediation of psychological distress have a positive and significant effect on the amount of spousal abuse (Fatehi et al., 2023). There is a positive and significant relationship between dark personality and spousal abuse (Carton & Egan, 2017). Psychopathy was found to be strongly related with direct cyber aggression behaviors; sadism was mainly related with cyber intimate partner violence victimization in both controlling and direct aggression, and, finally and interestingly, Machiavellianism presented negative correlations with direct cyber aggression (Pineda et al., 2022). Results showed that the relationships between participants' and partners' frequency of intimate partner violence varied depending on levels of dark tetrad traits (Plouffe et al., 2020). The actor-partner interdependence model showed that attachment anxiety and the dark triad were positively associated with psychological intimate partner violence perpetration 1 year later through different processes (Kanemasa et al., 2023). The moral disengagement mechanisms that explain both hostile and benevolent sexism were associated with Machiavellianism and psychopathy among perpetrators of sexual violence against women, whereas among community men, these mechanisms were associated with Machiavellianism and narcissism (Navas et al., 2022).

One of the other aims of the study was to investigate the mediating role of compassion for the others' lives in the

relationship between spouses' dark tetrad personality and verbal and lingual violence against women. In other words, the researchers sought to investigate the mediating role of compassion for the others' lives in intensifying the correlation between dark tetrad personality and verbal and lingual violence against married women. A research that examines the mediating effect of compassion for the others' lives in relation to dark tetrad personality and verbal and lingual violence against women has not been done yet, or at least the researchers didn't find it. But there are studies that show that compassion for the lives of others is effective in increasing the effect of psychological and personality variables including verbal and lingual violence and multiplies their effects (Ghaffari et al., 2022).

According to the above and reviewing the background of the research, it can be argued that parents' behavior and practices affect many aspects of family life, including health, and many studies have proven that children's bad habits are associated with parents' behavior and practices (Bushara, 2023). In recent years, the amount of verbal violence against women is increasing day by day, so that 20% to 40% of Southeast Asian women living in the United States reported family violence (Soglin et al., 2020). The amount of verbal violence in Iran is not at an acceptable level, so that 75% to 80% of the social emergency clients were girls and women who were involved in family violence, which verbal violence in the family causes emotional separation between couples and other members of Iranian families (Karampour et al., 2023). It is necessary for policymakers to adjust or reform the family system. Also according to few studies in the field of verbal violence against women and factors related to it, especially in the form of structural equations, multiplies the necessity of studying in this field. Therefore, the current research was conducted with the aim of determining the mediating role of compassion for the others' lives in the relationship between the spouses' dark tetrad personality and verbal violence against women.

Method

Participants

The method of the current research was descriptive/correlational. Clients of family court of Tabriz formed the population of the study in 2022, and two hundred from them were selected by using the availability sampling as the sample. After the sample was determined, the researcher, in coordination with the family court officials and following the health protocols, appeared in the waiting room of the family court and informed the clients about the importance and necessity of the research and emphasized that participation in the study is completely optional and non-participation In the study will not affect their trial process. After receiving informed consent, began to distribute information collection tools. For collect the data the researcher-made questionnaire of verbal and lingual

violence against women, compassion for the others' lives questionnaire (Chang et al., 2014) and the Johnson and Webster's dark tetrad personality scale (2010) was used.

Instrument

Questionnaire of verbal and lingual violence against women:

This questionnaire is a researcher-made scale which was designed by researchers to apply to married students of Payam Noor University. That, the perception of the acceptability of verbal aggression between intimate couples, it consisted of 16 scenarios covering a range of types of verbal aggression. Many of the scenarios involved experience occurring during conversation among intimate couples. In order to examine the reliability of the questionnaire, Cronbach's alpha coefficient, splitting and retesting of the questionnaire was obtained as 0.80, 0.72 and 0.88, respectively. Also, in order to examine the criterion validity of the questionnaire, the correlation of the questionnaire with the dimensions of the verbal violence against women questionnaire of the World Health Organization was examined and its correlation with the verbal, physical, and sexual violence subscales was obtained as 0.56, 0.65 and 0.69 respectively, which shows that The validity and reliability of the questionnaire is desirable (Ghaffari, 2022).

Questionnaire of compassion for the others' lives:

The compassion for the others' lives questionnaire was designed by Chang et al. (2014). It has 26 items that are graded on a 7-point Likert scale. The minimum and maximum score in this scale is 26 and 182, respectively, and a higher score reflects more compassion. Among the 26 items, 13 items are related to the empathy subscale and 13 items are related to the relief of pain and suffering subscale Hajlo and Ranjbar Noushri (2014). In order to examine the convergent and discriminant validity of the scale, they calculated through correlation with the emotional empathy scale and the abusive personality subscale, and significant results were obtained. The internal consistency of the scale was obtained based on Cronbach's alpha of 0.87 and the correlation of the items with the total score in

the range of 0.41 and 0.60, which shows the validity and reliability of the questionnaire.

The scale of dark tetrad personality:

The dark tetrad personality scale is a 21-item instrument designed by Johnson-Webster (2010). This scale includes four subscales: Machiavellianism, psychopathy, narcissism, and sadism and scored on a 5-point scale from (0 does not describe me at all) to (4 completely describes me). In their study, they confirmed the factorial structure as well as the validity of this scale. The validity of the Persian version of this questionnaire was reported by the internal consistency method (Cronbach's alpha) for the Machiavellian subscale, psychopathy, narcissism, and total score of 0.92, 0.40, and 0.68, respectively. In Iran, the coefficients of internal similarity calculated by Cronbach's alpha coefficient were narcissism 0.80, Machiavellianism 0.79, psychopathy 0.68, sadism 0.88 and for the whole scale 0.85. These results were obtained using the dichotomization method for the factors of narcissism 0.75, Machiavellianism 0.77, psychopathy 0.58, sadism 0.82 and for the whole scale 0.71. The coefficient of retesting the questionnaire after one week was 0.84 for the whole questionnaire 0.84 and for the factors of narcissism 0.81, Machiavellianism 0.78, psychopathy 0.76 and sadism 0.79. (Yousfi and Imanzad, 2017).

Statistical Analysis

The data was analyzed by using Pearson's correlation coefficient (to examine the simple matrix of variables) and path analysis (to determine the significance of the mediation relationships of the model) through SPSS and Amos software program with version 24, and $p < 0.05$ as a correlation was considered significant.

Results

The sample of the study included 200 women referring to the family court of Tabriz whose education level was 50 middle school, 40 high school, 47 diploma, 15 postgraduates, 19 bachelors and 25 postgraduate education. The mean, standard deviation, minimum and maximum scores of the variables are shown in Table 1.

Table 1. Descriptive statistics of variables

Variable	Mean	Std. Deviation	Minimum	Maximum
1. verbal and lingual violence against women	34.1	6.16	13	65
2. Machiavellianism	8.12	2.23	0	16
3. psychopathy	7.99	2.78	0	16
4. narcissism	8.22	2.53	0	16
5. sadism	15.7	3.65	0	36
6. compassion for the others' lives	100	12.8	26	182

In the structural equation method, Multivariate normality is one of the important assumptions that should be considered. One of the common criteria in examining the assumption of normality is the calculation of Skewness and elongation statistics. Based

on the contents of Table 2, because all research variables have absolute value of skewness coefficient smaller than 3 and have absolute value of elongation coefficient smaller than 10. Therefore, a violation of the normality of the data is not observable. Also, in order to

examine the simple correlation of predictor variables with verbal and lingual violence against women, Pearson's correlation matrix was used. The results presented in Table 2 show that there is a positive correlation between Machiavellianism ($r=0.19$), psychopathy ($r=0.29$), narcissism ($r=0.31$) and sadism ($r=0.351$) with verbal and lingual violence against

women is significant ($p<0.01$). But the correlation coefficient of compassion for the others' lives ($r=-0.23$) with verbal and lingual violence against women was negative and significant ($p<0.01$), which means that with the increase of compassion for the others' lives in wives, the amount of verbal abuse by their wives is reduced.

Table 2. Correlation matrix of variables

Variable	Kurtosis	Skewness	1
1. Verbal and lingual violence against women	0.469	0.191	-
2. Machiavellianism	0.5	0.23	0.19*
3. Psychopathy	0.12	0.34	0.29**
4. Narcissism	0.90	0.29	0.31**
5. Sadism	0.08	0.43	0.351**
6. Compassion for the others' lives	0.21	0.09	-0.23**

**Correlation significant at the 0.01 level (2-tailed)

For determining the significance of the mediation relationships of the model Bootstrap and Sobel tests were used. The results indicate that the dimensions of the spouses' dark tetrad personality in interaction with the mediating role of compassion for the others' lives play a role in explaining verbal and lingual violence against women, and a total of 27% of the variance of verbal and lingual violence against women is explained through the variables of the model. The direct effect of compassion for the others' lives (-0.19),

Machiavellianism (0.10), psychopathy (0.24), narcissism (0.23) and spouses' sadism (0.23) in estimating verbal violence against women is significant. The indirect effect of Machiavellianism (t -value = 2.81), psychopathy (t -value = 2.99) and sadism (t -value = 2.98) of spouses with the mediation of compassion for the others' lives on the level of verbal and lingual violence is significant against women. But the indirect effect of narcissism is not significant, the results are shown in Figure 1 and Table No. 3.

Table 3. Direct and indirect effect of variables on verbal violence against women

Paths	Direct Effect	Indirect Effect	Total Effect	p-value
1. Machiavellianism → Verbal violence against women	0.10	-	0.10	0.05
2. Psychopathy → Verbal violence against women	0.24	-	0.24	0.02
3. Narcissism → Verbal violence against women	0.23	-	0.23	0.02
4. Sadism → Verbal violence against women	0.23	-	0.23	0.01
5. Compassion for the others' lives → Verbal violence against women	-0.19	-	-0.19	0.03
6. Machiavellianism → Compassion for the others' lives	-0.05	-	-0.05	0.5
7. Psychopathy → Compassion for the others' lives	-0.24	-	-0.24	0.01
8. Narcissism → Compassion for the others' lives	-0.10	-	-0.10	0.04
9. Sadism → Compassion for the others' lives	-0.34	-	-0.488	0.00
10. Machiavellianism → Compassion for the others' lives → Verbal violence against women	-	0.009	0.109	0.06
11. Psychopathy → Compassion for the others' lives → Verbal violence against women	-	0.045	0.275	0.01
12. Narcissism → Compassion for the others' lives → Verbal violence against women	-	0.019	0.249	0.02
13. Sadism → Compassion for the others' lives → Verbal violence against women	-	0.064	0.294	0.00

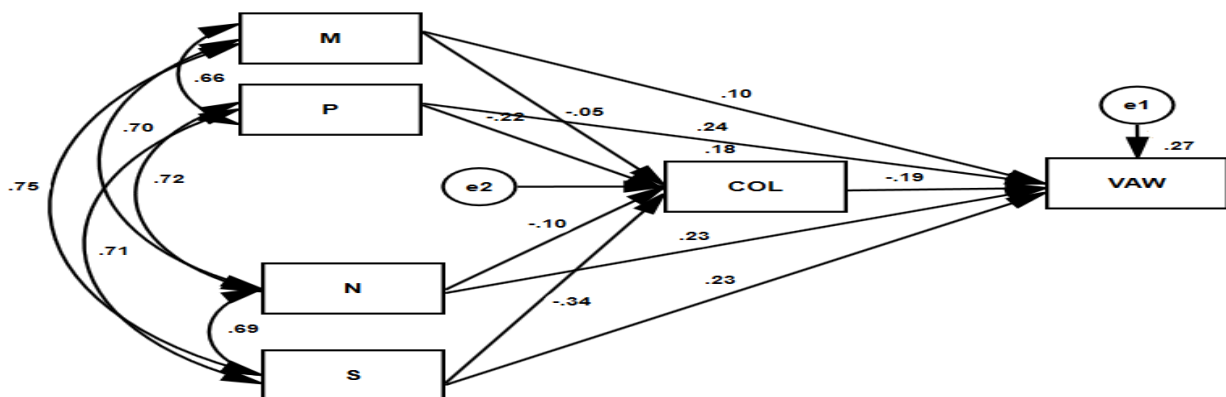

Fig.1. The standard coefficients of the final research model

Note: VAW= verbal violence against women; COL= compassion for the others' lives; M= Machiavellianism; P= psychopathy; N= narcissism; S= sadism

Amos version 24 software was used to measure the fit of the proposed model. The output showed that the mediating and input variables of the study are capable explain the model of verbal violence against women, because the values of the goodness-of-fit index or GFI, adjusted goodness-of-fit index or AGFI, incremental fit index or IFI and comparative fit index or CFI in the model is mostly 0.9. Also, in fit models, the index of chi-square ratio to the degree of freedom X^2/df should

be in the range of 1 to 3, and in this model, the index of the ratio of chi-square to the degree of freedom X^2/df is in the range of 1 to 3. In addition, the root mean square error of estimation index or RMSEA should be smaller than 0.09, which was obtained in this model as 0.08, which shows that the validity of this model is favorable. Therefore, the presented model is fully saturated. The results can be seen in Table No. 4.

Table 4. Fit the proposed pattern with data based on fit Indexes

Index	X^2	df	X^2/df	GFI	AGFI	IFI	CFI	RMSEA
Pattern	27	9	2.88	1	0.918	0.977	0.964	0.08

Note: X^2 = chi square; df = degrees of freedom; X^2/df = chi square ratio to degree of freedom; GFI = goodness of fit; AGFI = adjusted goodness of fit index; IFI = incremental fit index; CFI = comparative fit index; RMSEA = root mean square error of approximation.

Discussion

The first finding of the study showed that the direct effect of compassion for the others' lives on the level of verbal violence against women is positive and significant. Researches that are in line with this finding showed that the direct and indirect effect of empathy and compassion with the spouse on the level of verbal violence against women and spousal abuse was significant (Muralidharan & Kim, 2020). The role of spouses' compassion and empathy is significant in predicting different types of family violence (Covell et al., 2007). There is a statistically significant negative correlation between the total degrees of violence against the wife and the degrees of forgiveness with the husband and the total degrees of forgiveness of adult wives (El Sayed, 2023). About the findings obtained, it can be said that compassion in relation life means "having feelings for others" and is a leader in empathy. Husbands who sympathize with their wives can understand their wives' feelings well and even understand their feelings when they are angry and violent. In other words, compassion for the lives of others motivates husbands to help their wives physically, mentally, or emotionally. Also, according to the theory of self-service, compassion for the lives of others is a mutual characteristic and makes husbands show themselves responsible and kind to their wives until their wives and other family members act kindly and responsibly with them, the result of such a process is the reduction of verbal and lingual violence and verbal aggression in the context of the family.

The second finding of the study showed that the direct effect of spouses' narcissism on the amount of verbal and lingual violence against women is positive and significant. Researches that are in the same direction with this finding showed that narcissism and psychopathy (dimensions of the dark tetrad personality) are factors that affect the amount of spousal abuse and marital disturbances (Khaksari, 2022). Dark personality directly and through the mediation of psychological

distress have a positive and significant effect on the amount of spousal abuse (Fatehi et al., 2023). There is a positive and significant relationship between dark personality traits and spousal abuse (Carton & Egan, 2017). It can be said that the base and foundation of dark personality traits is the foundation of emotional defects that cause these people to be unable to control and manage their emotions, especially anger, abuse their spouses, and show verbal and linguistic violence to them, enjoy harming their spouse and other family members and make the home environment unsafe for other family members. In another explanation, it can be said that husbands who are narcissistic consider themselves deserving of everything. Therefore, they use all ways and methods to achieve their goals and desires. Even by committing verbal and lingual, mental, economic and sexual violence to the wife and other family members.

The next finding of the study was that psychopathy is significant in explaining the model of verbal violence against women. Given that one of the main characteristics of psychopaths is the lack of remorse and shame for hurting others (Almeida et al, 2023). Therefore, in this type of people, the possibility of verbal attack and violence against others, especially the spouse, is not far from expected, because the lack of remorse makes them feel satisfied with the action. Also, the results of the study showed the role of Machiavellianism in explaining the model of verbal violence against women. Machiavellianism is a personality trait characterized by a calculating attitude toward human relationships and the belief that the end justifies the means. In other words, a Machiavellian character is someone whom others (including their spouse) see as objects that they must use verbal and linguistic violence against to further their goals, if necessary (Brewer & Abell, 2015).

In this study, sadism was another dark dimension of personality, that its direct effect on the amount of verbal violence against the wife was significant. The results of

the research consistent with the present finding showed that sadism is a type of mental disorder in which the patient has a tendency to torture and feels satisfaction after doing it (Thomas & Egan, 2022). This harassment by the spouse can appear in different ways including verbal and linguistic harassment.

The last hypothesis of the study was that the mediating role of compassion for the others' lives is significant in the relationship between four dark personality traits and verbal and lingual violence against women. The result of the Sobel test showed the indirect effect of Machiavellianism (t-value = 2.81), psychopathy (t-value = 2.99) and sadism (t-value = 2.98) of spouses with the mediation of compassion to the verbal and lingual violence against women is significant to the lives of others. The obtained result is aligned with the study of Ghaffari et al (2022), who showed that the variable role of compassion for the others' lives is significant in the relationship between psychological and family variables. Based on the association network model, it can be said that spouses who are equipped with compassion for the lives of others, all their behaviors and great processes of their minds are accompanied by kindness and compassion, in other words, the perception they have of their spouse's behavior and words is accompanied by kindness and compassion, as a result, they try to treat their spouses with kindness and friendship instead of threats and verbal and lingual violence. Also, husbands' kindness acts like a filter in them and it causes the correlation between dark and undesirable personality traits and characteristics to be reduced or moderated therefore, the correlation between spousal abuse and dark personality traits is broken, and love and intimacy are replaced by verbal and lingual domestic violence.

Considering the significant role of the variable of compassion for the others' lives in moderating the relationship between spouses' dark tetrad personality and verbal and lingual violence against spouses, it is suggested to researchers and students that the variable effect of compassion for the others' lives on dark personality and verbal and lingual violence against spouses should be investigated in an interventional way. Among the limitations that the researchers tried to reduce was the control of the participants' concern about being infected of the question papers and pens with the corona virus due to the simultaneous implementation of the study with the outbreak of the Covid-19 disease, which is the possibility of not answering the questions correctly because of compliance with health protocols increased.

Conclusion

The results of the study showed that the variable of compassion for the others' lives is effective in moderating the relationship between spouses' dark tetrad personality and verbal and lingual violence against spouses, and it has reduced the effect of dark personality in the formation of spousal abuse. Therefore, in order to weaken the negative effects of dark personality in

intensifying verbal and lingual violence against wives and wife abuse, it is necessary for husbands to be aware of the role of compassion for the others' lives and use it in solving marital, life and children's issues.

Disclosure Statement

No potential conflict of interest was reported by the authors.

ORCID

Mozaffar Ghaffari: <https://orcid.org/0000-0001-6901-7132>

References

- Ahmadi, E., Mirmohamadi, F., & yaghoubi, H. (2023). The effectiveness of self-compassion training on the intensity of chronic pain in women under domestic violence. *Journal of Research in Psychopathology*, 4(14). doi:10.22098/jrp.2023.13281.1188
- Alkan, Ö., Serçemeli, C., & Özmen, K. (2022). Verbal and psychological violence against women in Turkey and its determinants. *PLoS one*, 17(10), e0275950. doi:10.1371/journal.pone.0275950
- Almeida, I., Nobre, C., Marques, J., & Oliveira, P. (2023). Violence against women: attachment, psychopathology, and beliefs in intimate partner violence. *Social Sciences*, 12(6), 346-355. doi: org/10.3390/socsci12060346
- Brewer, G., & Abell, L. (2015). Machiavellianism in long-term relationships: Competition, mate retention and sexual coercion. *Scandinavian Journal of Psychology*, 56(3), 357-362. doi:10.1111/sjop.12200
- Bushara, M.O.E. (2023). The influence of parent's behavior and practice on their family Health. *Preprints*, 20, 1-8. doi:10.20944/preprints202302.0504.v1
- Carton, H., & Egan, V. (2017). The dark triad and intimate partner violence. *Personality and Individual Differences*, 105, 84-88. doi:10.1016/j.paid.2016.09.040
- Chang, J.H., Fresco, J., & Green, B. (2014) The development and validation of the compassion of others' lives scale. *International Journal Human Society Science*, 4(5), 33-42.
- Covell, C. N., Huss, M. T., & Langhinrichsen-Rohling, J. (2007). Empathic deficits among male batterers: A multidimensional approach. *Journal of Family Violence*, 22, 165-174.
- Effiong, J. E., Ibeagha, P. N., & Iorfa, S. K. (2022). Traumatic bonding in victims of intimate partner violence is intensified via empathy. *Journal of Social and Personal Relationships*, 39(12), 3619-3637. doi:10.1177/0265407522110623
- El Sayed, H. E. S. S. (2023). Violence against the wife and its relationship to forgiveness on a sample of adult wives. *Journal of Education Sohag UNV*, 107(107), 601-767. doi:10.21608/edusohag.2023.288946

- Fatehi, S., Moradi, O., & Yousefi, F. (2023). Developing a model of experiencing spousal violence in women based on personality traits with a mediating role of psychological distress. *Shenakht Journal of Psychology and Psychiatry*, 9 (6), 1-15. doi:10.32598/shenakht.9.6.1
- Ghaffari, M. (2022). Explanation of the mediating role of compassion for the others' lives in the relationship between the spouses' dark tetrad personality and verbal and lingual violence against women. Research project of Payame-Noor University; Tehran, Iran.
- Ghaffari, M., Khani, L., & Mahmmodi, A. (2022). Presenting a Structural Model to Explain Compassionate Care of Nurses Based on Moral Identity and Compassion to Others' Lives. *Iranian Journal of Medical Ethics and History of Medicine*, 15(1), 253-265. doi 10.18502/ijme.v15i18.11823
- Hosseinabadi, M., Amirahmadi, R., Esmaeili, A., & Naeimi, M. (2021). The Process of Violence against Women in Iran and the World: Providing Solutions to Reduce Violence based on the Experience of Countries. *IAU International Journal of Social Sciences*, 11(4), 101-116.
- Jafari, Z., & Parvin, F (2022). An over of types of violence against women in Iran between 2010 and 2021. *Nursing and Midwifery Journal*, 20 (4), 269-279. doi:10.52547/unmf.20.4.269
- Kanemasa, Y., Asano, R., Komura, K., & Miyagawa, Y. (2023). The longitudinal associations between personality traits and psychological intimate partner violence. *Journal of marriage and family*, 85(1), 55-71. doi:10.1111/jomf.12869
- Karampour, R., Alahnoori, A., & Ghasemi, Z. (2023). Investigating lived experiences and factors affecting family violence in new generation families (Couples less than 30 years old) Ilam city. *Socio-Cultural Strategy*, 11(4), 377-402. doi:10.22034/scs.2022.161683
- Khaksari, B. (2022). The relationship between dark personality traits with marital disorders of Kermanshah nursing couples in Covid-19 crisis. *Paramedical Sciences and Military Health*, 16 (3), 30-37.
- Muralidharan, S., & Kim, E. A. (2020). Can empathy offset low bystander efficacy? effectiveness of domestic violence prevention narratives in India. *Health communication*, 35(10), 1229-1238. doi:10.1080/10410236.2019.1623645
- Güneş, A., & Ezikoğlu, Ç. (2023). Legal and political challenges of gender equality and crimes against women in Turkey: The question of Istanbul convention. *Women & Criminal Justice*, 33(1), 14-27. doi:10.1080/08974454.2022.2040695
- Navas, M. P., Maneiro, L., Cutrín, O., Gómez-Fraguela, J. A., & Sobral, J. (2022). Sexism, moral disengagement, and dark triad traits on perpetrators of sexual violence against women and community men. *Sexual Abuse*, 34(7), 857-884. doi:10.1177/10790632211051689
- Pineda, D., Galán, M., Martínez-Martínez, A., Campagne, D. M., & Piqueras, J. A. (2022). Same personality, New ways to abuse: How dark tetrad personalities are connected with cyber Intimate partner violence. *Journal of Interpersonal Violence*, 37(13-14), 11223-11241. doi:10.1177/0886260521991307
- Plouffe, R. A., Wilson, C. A., & Saklofske, D. H. (2020). The role of dark personality traits in intimate partner violence: A multi-study investigation. *Current Psychology*, 1-20. doi:10.1007/s12144-020-00871-5
- Pommier, E.A. (2011). The compassion scale: dissertation abstracts international (Section A). *Human Society Science*, 72, 1174-80.
- Soglin, L. F., Ragavan, M., Immaneni, S., & Soglin, D. F. (2020). Assessing intimate partner violence in South Asian women using the index of spouse abuse. *Violence Against Women*, 26(6-7), 697-711. doi:10.1177/1077801219842945
- Thomas, L., & Egan, V. (2022). A systematic review and meta-analysis examining the relationship between everyday sadism and aggression: Can subclinical sadistic traits predict aggressive behavior within the general population? *Aggression and violent behavior*, 65, 101750. doi:10.1016/j.avb.2022.101750
- Weng, H. Y., Fox, A. S., Shackman, A. J., Stodola, D. E., Caldwell, J. Z., Olson, M. C., ... & Davidson, R. J. (2013). Compassion training alters altruism and neural responses to suffering. *Psychological science*, 24(7), 1171-1180. doi:10.1177/0956797612469537
- Yousefi, R., & Imanzad, A.(2018). Validating the Dark Tetrad Personality Model. *Iranian Journal of Psychiatry and Clinical Psychology*, 24 (2),190-201.doi:10.32598/ijpcp.24.2.190